Operating instructions

Solenoid valves

Product series

Type 210

Type 210a

Type 214

Type 215

Type 216

Type 219

Type 220

Type 221

Type 240

Type 242

Type 246

Type 310

Type 314

Type 317

AWS Apparatebau Arnold GmbH
Zimmerbachstraße 51
74676 Niedernhall - Waldzimmern

FON +49 (0)7940 9308-200

FAX +49 (0)7940 9308-212

MAIL info@aws-apparatebau.de

WEB www.aws-apparatebau.de

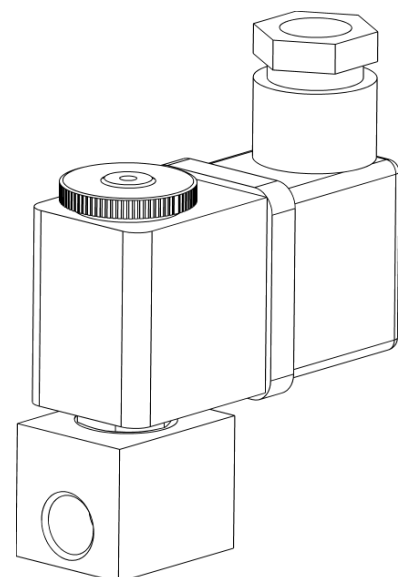

TABLE OF CONTENTS

SOLENOID VALVES

1	PREFACE	1
1.1	General information	1
1.2	Target group	1
1.2.1	Personnel qualification	1
1.3	Applicable documents	1
1.4	Warranty	1
2	SAFETY INSTRUCTIONS	2
2.1	Warnings.....	2
2.2	Intended use	2
2.3	User requirements	2
2.4	General safety instructions.....	3
3	VALVE DESCRIPTION	5
3.1	Product series	8
3.2	Intended use	13
3.3	Functional description	13
3.4	Scope of delivery	13
4	TYPE PLATE	14
4.1	Breakdown of the article description.....	14
5	STORAGE AND TRANSPORT	15
6	INSTALLATION	16
6.1	Prepare installation	16
6.2	Planning pipelines.....	17
6.3	Installation instructions.....	17
6.3.1	Threaded connection	17
6.3.2	Flange connection	17
6.4	Electrical connection	18
6.4.1	Pin assignment.....	18
7	COMMISSIONING; DECOMMISSIONING; MAINTENANCE	19
7.1	Commissioning	19
7.2	Decommissioning.....	19
7.3	Maintenance	20
7.4	Remove pollutants	20
7.5	Pressure test the system.....	20
7.6	Eliminate faults and defects	21
8	DISASSEMBLY	22
8.1	Prepare disassembly	22
8.2	Electrical disassembly.....	22
8.3	Mechanical disassembly	22

9	STORE / REUSE VALVE	23
10	DISPOSAL	23
11	MAINTENANCE	24
11.1	Coil change.....	24
11.2	Spare parts	25
11.3	Reshipment.....	25
12	DECLARATION OF CONFORMITY	26
13	APPENDIX	26
13.1	Technical data.....	26
13.2	Circuit diagram.....	26

1 PREFACE

These operating instructions will help you to use the following valves correctly, safely and economically:

- 210, 210a, 214, 215, 216, 219, 220, 221, 240, 242, 246, 310, 314 and 317

1.1 General information

These operating instructions apply to all the above-mentioned valves. To ensure safe and efficient operation, the entire manual must be read and understood before installation and commissioning. This is intended to support the user during assembly, operation, maintenance and disassembly. In addition to the instructions in the manual, all applicable accident prevention regulations, safety rules, country or system-related regulations and provisions must also be observed. These operating instructions are an integral part of the valve and must be kept available by the operator at the place of use for later use.

1.2 Target group

The instructions are intended for any person involved in work of any kind on the valve. In particular, the operating instructions are intended for trained and qualified technical personnel.

1.2.1 Personnel qualification

All work on the valve may only be carried out by qualified specialist personnel. If the personnel do not have the required qualifications, they must be trained. This must be ensured by the operator. Persons without the required knowledge and skills are not permitted to work on the valve, or only under the supervision of qualified technical personnel.

1.3 Applicable documents

This includes the corresponding data sheet and the declaration of conformity for the above-mentioned valves. If necessary, these must be requested from the manufacturer or downloaded from the website.

1.4 Warranty

AWS Apparetebau Arnold GmbH does not assume any warranty if the operator or third parties:





- disregard this document.
- do not insert the valve properly.
- should carry out any kind of work on the valve (conversions, modifications, etc.).

Malfunctions due to soiling or wear of the valve and wearing parts (e.g. seals) are not covered by the warranty.

2 SAFETY INSTRUCTIONS

2.1 Warnings

In these instructions, the following warnings are used. To protect you from accidents, injuries and damage to property, it is important to read and observe these warnings.

	DANGER
	<p>High risk Indicates an imminent danger. If it is not avoided, death or serious injury will result.</p>
	WARNING
	<p>Medium risk Indicates a potentially dangerous situation. If it is not avoided, death or serious injury may result.</p>
	CAUTION
	<p>Low risk Indicates a potentially dangerous situation. If it is not avoided, slight or minor injuries may result.</p>
	NOTICE
	<p>Regulation Indicates a potentially harmful situation. If it is not avoided, material damage may result.</p>

2.2 Intended use

AWS valves may only be used within the approved pressure and temperature limits, taking into account chemical and corrosive influences. The valves are not suitable for media containing solids. Intended use includes observing and following the instructions in this manual. Modifications, conversions or improper use of the valve are considered improper use.

2.3 User requirements

It is the responsibility of the planner, installer and operator to ensure that:

- the valve is used as described in chapter 2.2 (Intended use).
- the pipe system is installed correctly and its proper functioning must be checked regularly.
- only qualified personnel are used for assembly, disassembly, maintenance and work on the electrical system.
- the valve is only installed by a professional in perfect condition.
- the operating instructions are observed by the personnel.
- the personnel receives regular instruction in occupational safety and environmental protection (especially for pressurized pipes).

2.4 General safety instructions

The same regulations apply to all valves as to the piping systems in which they are installed. The national and international regulations of the operator with regard to accident prevention and safety regulations must be observed.



In particular, the following general safety instructions must be observed:

	DANGER
	<p>During work on the system</p> <ul style="list-style-type: none"> ▪ The system must be switched off and secured against unauthorized activation. ▪ The pipeline must be depressurized to prevent uncontrolled leakage of the medium. ▪ The pipe system must have cooled down to approx. 20°C. ▪ Medium must be completely removed from the valve and pipe. ▪ Contaminated valve must be completely decontaminated before any work is carried out there. ▪ Valves may only be installed, removed and maintained by qualified personnel. ▪ Electrical installations may only be carried out by a qualified electrician or instructed persons under the supervision of a qualified electrician.

	DANGER
	<p>During operation of the system and valve</p> <ul style="list-style-type: none"> ▪ In applications with a risk of explosion, hot surfaces of the system and valve parts can be a potential source of ignition. This risk must be taken into account by the operator of the system.

	WARNING
	<p>During work on the system</p> <ul style="list-style-type: none"> ▪ Any residual liquid that escapes during disassembly must be collected and disposed of.

	WARNING
	<p>Operation of the system and the valve</p> <ul style="list-style-type: none"> ▪ Only use media that will not damage the valve and associated seals (suitable material pairing). Otherwise, this can lead to leakage and escape of the medium. ▪ When using media at high temperatures, contact with the system parts and the valve can cause burns. In this case, these should not be touched or only with suitable protective equipment. This is the responsibility of the operator of the system.

	CAUTION
	Risk of minor injuries <ul style="list-style-type: none">▪ Wear protective gloves during assembly, disassembly and maintenance to avoid cutting yourself on sharp-edged components.
	NOTICE
	Indication of material damage <ul style="list-style-type: none">▪ Incorrect installation can damage the valve and system.

3 VALVE DESCRIPTION

The following illustrations describe the design of the above product series. Only one type is shown as an example; the design of the valves may differ slightly.

210* / 210a / 214 / 215 / 216 / 219

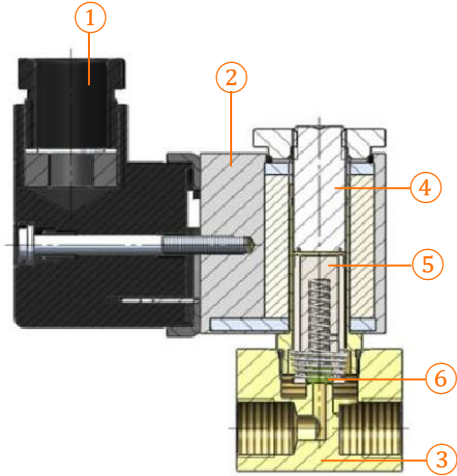
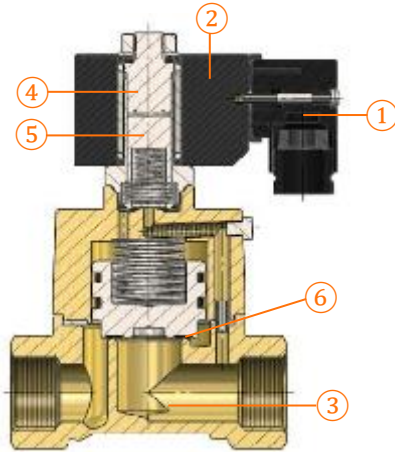

*Illustration of type 210

Pos.	Designation
1	Plug socket
2	Coil
3	Valve body
4	Magnetic sleeve
5	Plunger
6	Sealing

The valves are direct acting seat valves. No differential pressure is required for opening or closing.

246



Pos.	Designation
1	Plug socket
2	Coil
3	Valve body
4	Magnetic sleeve
5	Plunger
6	Sealing

The valve is a pilot operated seat valve with piston. A differential pressure of 0.5 bar is required between the inlet and outlet for opening and closing.

220* / 240

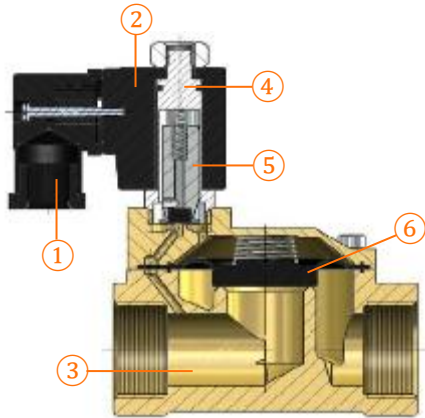

* Illustration of type 220

Pos.	Designation
1	Plug socket
2	Coil
3	Valve body
4	Magnetic sleeve
5	Plunger
6	Sealing

The valves are pilot operated poppet valves with a diaphragm seal and require a differential pressure to open and close. Type 220 requires a differential pressure between inlet and outlet of 0.1 bar. Type 240 requires a differential pressure between inlet and outlet of 0.5 bar.

221 / 242*

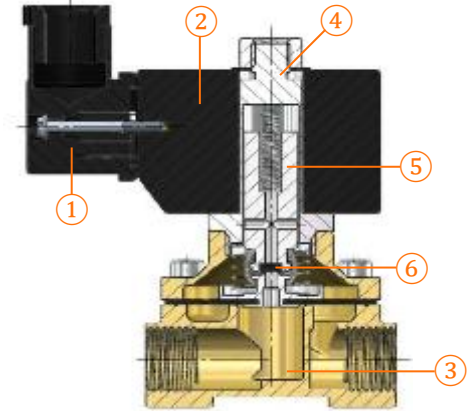

* Illustration of type 242

Pos.	Designation
1	Plug socket
2	Coil
3	Valve body
4	Magnetic sleeve
5	Plunger
6	Sealing

The valves are force pilot operated valves with diaphragm seal and forced lifting. There is no differential pressure required for opening or closing.

310 / 314* / 317

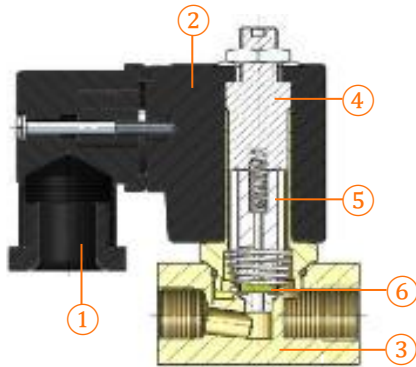

The valves are direct acting valves. No differential pressure is required for opening or closing.

* Illustration of type 314

Pos.	Designation
1	Plug socket
2	Coil
3	Valve body
4	Magnetic sleeve
5	Plunger
6	Sealing

3.1 Product series

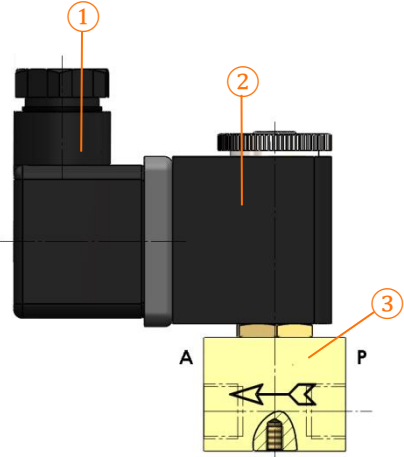
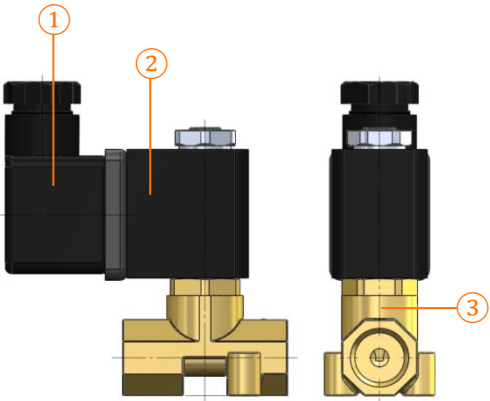
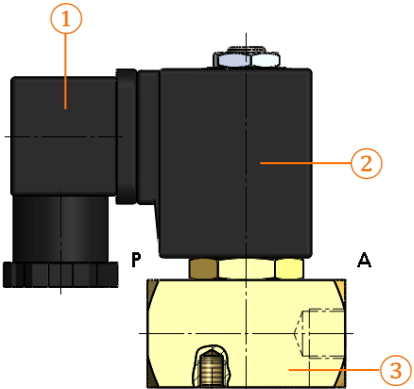
Product series	Characteristics		
Type 210	Pos.	Designation	Material
	1	Plug socket	Plastic
	2	Coil housing	Plastic or metal
	3	Valve body	Brass or stainless steel
	✕	Sealing material	FKM
	<ul style="list-style-type: none"> ▪ DN1,0 - DN2,5 ▪ Direct acting ▪ Connection G1/8" ▪ Plug socket acc. to DIN EN 175301-803 plug type B 		
Type 210a	Pos.	Designation	Material
	1	Plug socket	Plastic
	2	Coil housing	Plastic or metal
	3	Valve body	Messing
	✕	Sealing material	NBR, EPDM or FKM
	<ul style="list-style-type: none"> ▪ DN1,0 - DN2,5 ▪ Direct acting ▪ Connections G1/8" - G1/4" ▪ Plug socket acc. to DIN EN 175301-803 plug type B 		
Type 214	Pos.	Designation	Material
	1	Plug socket	Plastic
	2	Coil housing	Plastic or metal
	3	Valve body	Brass or stainless steel
	✕	Sealing material	NBR, EPDM or FKM
	<ul style="list-style-type: none"> ▪ DN2,0 - DN6,0 ▪ Direct acting ▪ Connection G1/4" ▪ Plug socket acc. to DIN EN 175301-803 plug type A 		

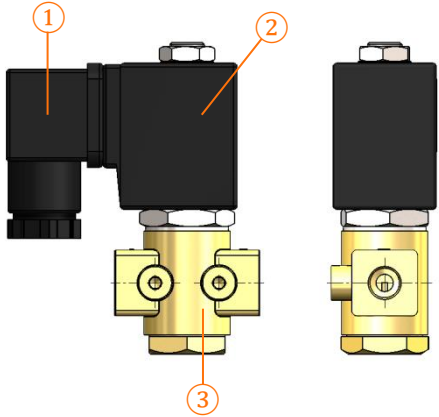
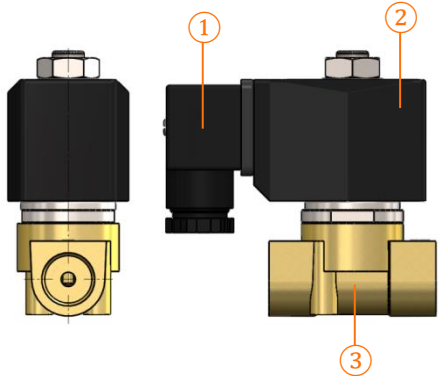
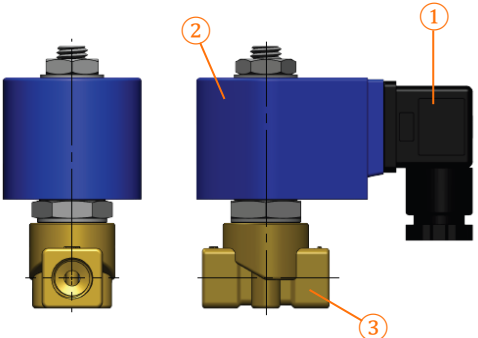
Product series	Characteristics		
Type 215	Pos.	Designation	Material
	1	Plug socket	Plastic
	2	Coil housing	Plastic or metal
	3	Valve body	Brass or stainless steel
	✕	Sealing material	NBR, EPDM or FKM
		<ul style="list-style-type: none"> ▪ DN1,0 - DN4,0 ▪ Direct acting ▪ Connections G1/8" - G1/4" ▪ Plug socket acc. to DIN EN 175301-803 plug type A 	
Type 216	Pos.	Designation	Material
	1	Plug socket	Plastic
	2	Coil housing	Plastic or metal
	3	Valve body	Brass or stainless steel
	✕	Sealing material	NBR, EPDM or FKM
		<ul style="list-style-type: none"> ▪ DN5,0 - DN10 ▪ Direct acting ▪ Connections G1/8" - G1/2" ▪ Plug socket acc. to DIN EN 175301-803 plug type A 	
Type 219	Pos.	Designation	Material
	1	Plug socket	Plastic
	2	Coil housing	Plastic or metal
	3	Valve body	Brass or stainless steel
	✕	Sealing material	NBR, EPDM or FKM
		<ul style="list-style-type: none"> ▪ DN2,0 – DN7,5 ▪ Direct acting ▪ Connections G1/8" - G1/2" ▪ Plug socket acc. to DIN EN 175301-803 plug type A 	

Product series	Characteristics		
Type 220	Pos.	Designation	Material
	1	Plug socket	Plastic
	2	Coil housing	Plastic or metal
	3	Cover	Brass or stainless steel
	4	Valve body	Brass or stainless steel
	✕	Sealing material	NBR, EPDM or FKM
	<ul style="list-style-type: none"> ▪ Brass DN10,5; Stainless steel DN8,0 ▪ Pilot operated ▪ Connections G1/4" – G1/2" ▪ Plug socket acc. to DIN EN 175301-803 plug type A 		
Type 221	Pos.	Designation	Material
	1	Plug socket	Plastic
	2	Coil housing	Plastic or metal
	3	Cover	Brass or stainless steel
	4	Valve body	Brass or stainless steel
	✕	Sealing material	NBR, EPDM or FKM
	<ul style="list-style-type: none"> ▪ DN10; DN13 ▪ Force pilot operated ▪ Connections G1/4" - G1/2" ▪ Plug socket acc. to DIN EN 175301-803 plug type A 		
Type 240	Pos.	Designation	Material
	1	Plug socket	Plastic
	2	Coil housing	Plastic or metal
	3	Cover	Brass or stainless steel
	4	Valve body	Brass or stainless steel
	✕	Sealing material	NBR, EPDM or FKM
	<ul style="list-style-type: none"> ▪ DN5,0 - DN10 ▪ Direct acting ▪ Connections G1/8" - G1/2" ▪ Plug socket acc. to DIN EN 175301-803 plug type A 		

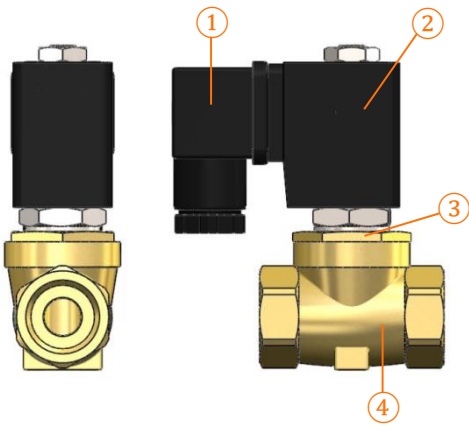
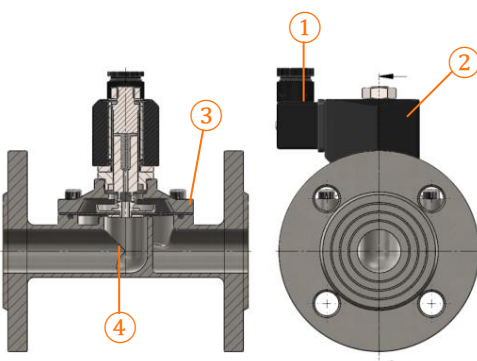
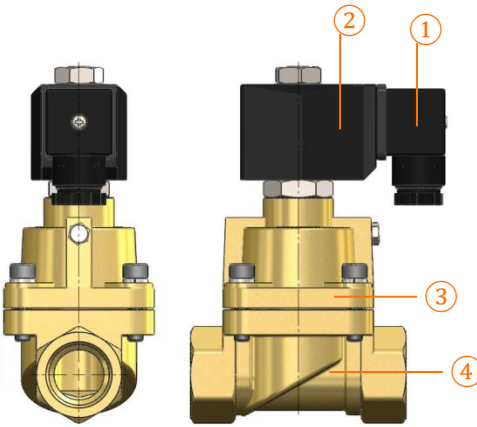
Product series	Characteristics		
Type 242	Pos.	Designation	Material
	1	Plug socket	Plastic
	2	Coil housing	Plastic or metal
	3	Cover	Brass or stainless steel
	4	Valve body	Brass or stainless steel
	⊗	Sealing material	NBR, EPDM or FKM
	<ul style="list-style-type: none"> ▪ Brass DN 10,5; Stainless steel DN8,0 ▪ Pilot operated ▪ Connections G3/8" - G2" ▪ Plug socket acc. to DIN EN 175301-803 plug type A 		
Type 242 FL	Pos.	Designation	Material
	1	Plug socket	Plastic
	2	Coil housing	Plastic or metal
	3	Cover	Brass or stainless steel
	4	Valve body	Brass or stainless steel
	⊗	Sealing material	NBR, EPDM or FKM
	<ul style="list-style-type: none"> ▪ DN15 - DN100 ▪ Force pilot operated ▪ Flange connection acc. to DIN EN 1092-1 		
Type 246	Pos.	Designation	Material
	1	Plug socket	Plastic
	2	Coil housing	Plastic or metal
	3	Cover	Brass or stainless steel
	4	Valve body	Brass or stainless steel
	⊗	Sealing material	NBR, EPDM or FKM
	<ul style="list-style-type: none"> ▪ DN15 - DN50 ▪ Pilot operated ▪ Connections G3/8" - G2" ▪ Plug socket acc. to EN 175301-803 plug type A 		

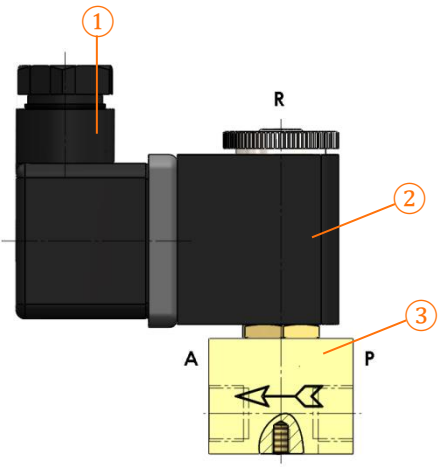
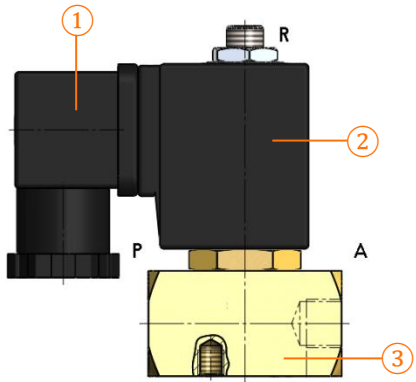
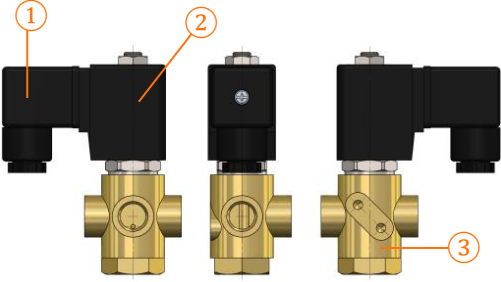
Product series	Characteristics		
Type 310	Pos.	Designation	Material
	1	Plug socket	Plastic
	2	Coil housing	Plastic or metal
	3	Valve body	Brass or stainless steel
	✕	Sealing material	FKM
	<ul style="list-style-type: none"> ▪ DN1,0 - 2,0 ▪ Direct acting ▪ Connection G1/8" ▪ Plug socket acc. to DIN EN 175301-803 plug type B 		
Type 314	Pos.	Designation	Material
	1	Plug socket	Plastic
	2	Coil housing	Plastic or metal
	3	Valve body	Brass or stainless steel
	✕	Sealing material	NBR, EPDM or FKM
	<ul style="list-style-type: none"> ▪ DN1,0 - DN2,5 ▪ Pilot operated ▪ Connection G1/4" ▪ Plug socket acc. to DIN EN 175301-803 plug type A 		
Type 317	Pos.	Designation	Material
	1	Plug socket	Plastic
	2	Coil housing	Plastic or metal
	3	Valve body	Brass or stainless steel
	✕	Sealing material	NBR, EPDM or FKM
	<ul style="list-style-type: none"> ▪ DN1,5 - DN4,0 ▪ Direct acting ▪ Connections G1/8" - G1/4" ▪ Plug socket acc. to DIN EN 175301-803 plug type A 		

3.2 Intended use

The solenoid valve is used to control media or to open and close pipelines. They are designed for direct installation between two pipelines. The mentioned valves are suitable for use in piping systems for the transportation of liquid and gaseous fluids. The valves are not suitable for solids. The valves only seal in the flow direction of the media flow.

3.3 Functional description

The valves are opened or closed by magnetic force. They are available either normally closed (NC) or normally open (NO). There is a plunger in the valve, which is actuated by applying power to an electromagnet. This plunger is connected to the seat seal or a diaphragm (depending on the valve type), which is used to seal the main valve bore or control bore. Depending on the operating type of the valve, it switches under direct acting, pilot operated or force pilot operated. More detailed data can be found in the valve description or data sheets. After the power is applied to the coil, the plunger is returned to the starting position by a return spring. AWS Apparatebau valves are fully automatic, glandless and therefore practically maintenance-free.

3.4 Scope of delivery

The valve is supplied ready for installation.

4 TYPE PLATE

A type plate is attached to each valve. The characteristics of the valve are listed on this type plate.

The following illustration shows the structure of the type plates of the above-mentioned valves.

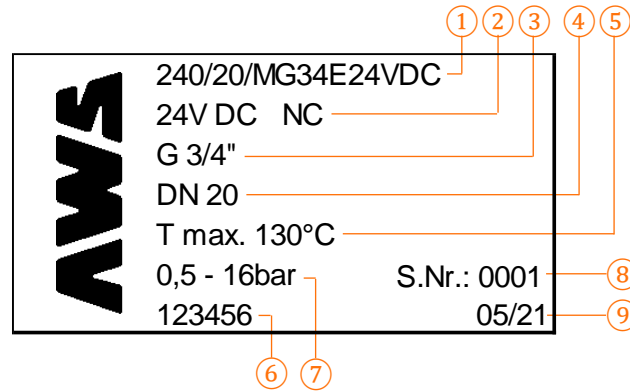

- | | |
|--|-----------------------|
| ① Article description | ⑥ Commission number |
| ② Nominal voltage /
Switch function | ⑦ Pressure range |
| ③ Connection | ⑧ Serial number |
| ④ Nominal sizes | ⑨ Date of manufacture |
| ⑤ Max. temperature | |

4.1 Breakdown of the article description

The following breakdown is an example of a standard valve for illustrative purposes.

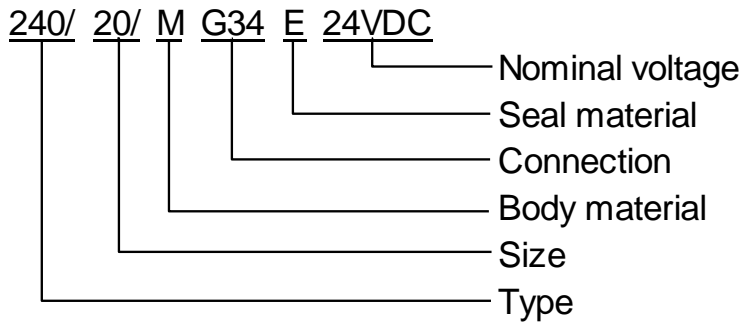

5 STORAGE AND TRANSPORT

The valve is supplied in a ready-to-use condition. When storing and transporting the valve, there are a number of guidelines that the user must observe in order to guarantee perfect operation later on.

Storage:

- The valve must be stored in its original packaging in closed rooms in a dry, frost-free and shockproof environment. (Storage temperature +10°C to +50°C)
- The valve must be protected from harmful influences (e.g. moisture or dirt) during storage.
- Valves with sealing elements made of organic materials (e.g. EPDM) must be stored away from sunlight and UV light to prevent them from aging more quickly.
- Do not store chemicals, solvents, acids, etc. in the same room as the valve.
- The valve must be protected against mechanical damage during storage. Special attention must be paid to protecting the connection surfaces.
- In order to achieve short storage times, existing stocks should be used first (first in - first out).
- If stored for too long, the seals may have aged significantly, which can lead to malfunctions.

Transport:

- The same guidelines apply for transport as for the storage.
- For transportation over long distances, the valve must be transported in suitable packaging. If the original packaging has been removed, the valve must be packed in equivalent packaging to protect it from mechanical damage and corrosion.
- Secure the valve adequately during transport.

6 INSTALLATION

The operator of the system is generally responsible for the design of the pipelines and the installation of the valve. The function may be affected by planning and installation errors.

6.1 Prepare installation

- Remove the valve from the packaging.
- Check the valve for completeness and transport damage.
- If incompleteness or damage is detected, contact the manufacturer.
- Damaged valves/components must not be installed.
- Ensure that the type plate details match the order and design data.
- When installing, dispose of packaging material in accordance with local regulations.



	DANGER
	<p>Accident prevention before installation</p> <ul style="list-style-type: none"> ▪ Pipes of the system must be depressurized. ▪ Ensure that the pipes and valve have cooled down to room temperature. ▪ System must be free of hazardous media. ▪ System must be switched off and secured against being switched on again. ▪ If necessary, use the appropriate safety equipment.

	DANGER
	<p>Incorrectly connected valve</p> <ul style="list-style-type: none"> ▪ The valve may only be installed by qualified personnel. ▪ Flow direction arrow of the valve must match the flow direction of the pipeline. ▪ Only install valves whose pressure class, chemical resistance, connection and dimensions correspond to the operating conditions. ▪ Valve may only be used within the intended application limits. ▪ Pipes must be drained and cleaned if necessary.

	NOTICE
	<p>Notes on installing the valve</p> <ul style="list-style-type: none"> ▪ The system must be clean and free of foreign matter at the installation point (connections, flanges). ▪ Install the valve horizontally or vertically. ▪ Install the valve with the preferably facing upwards. ▪ Ensure that no impurities enter the valve. If necessary, flush the system with a neutral medium.

6.2 Planning pipelines

There are a number of requirements that need to be taken into account when designing the pipeline.

	DANGER
	<p>Incorrectly planned pipeline</p> <ul style="list-style-type: none"> ▪ Planning and installation of the piping may only be performed by qualified personnel.
	WARNING
	<p>Leakage due to impermissible pipe forces</p> <ul style="list-style-type: none"> ▪ Sicherstellen, dass keine Zug- oder Druckkräfte sowie keine Biegemomente auf das Ventil wirken.
	NOTICE
	<p>Dimensioning of the pipeline</p> <ul style="list-style-type: none"> ▪ Compensate for changes in length due to temperature fluctuations. ▪ Observe the installation position and installation direction of the valve. ▪ Provide measures to prevent pressure surges. ▪ Use strainers for proper function.

6.3 Installation instructions

The valve is installed according to the type of pipe connection.

6.3.1 Threaded connection

- Screw the threaded connection into the pipe in accordance with the applicable standard.
- Use suitable sealing material depending on the design and intended use. (Sealing material not included in the scope of delivery)

6.3.2 Flange connection

- Carefully align the flanges before tightening the screws.
- Center the seals (use suitable sealing material).
- Connect the valve flange and pipe flange with a suitable gasket and screws.
- Tighten the screws crosswise. Use all flange holes!
- Only use approved connecting elements.

6.4 Electrical connection

The following instructions and operating steps must be followed for the electrical connection of the valve:

	DANGER
	<p>Risk of death due to electrocution</p> <ul style="list-style-type: none"> Only allow a qualified electrician to carry out work on the electrical system. Switch off the power supply to the system and secure it against being switched on again. The protective conductor must be connected to the designated and marked point. Observe applicable accident prevention regulations and safety regulations for electrical devices.

	NOTICE
	<p>Indications of material damage to electrical components</p> <ul style="list-style-type: none"> Ensure the correct power type and voltage before connecting. Protect the plug socket connection from permanent moisture. Provide a cover if required.

- Connect the cable to the plug socket.
- Plug the plug socket into the socket of the valve. Ensure that the cable pin assignment is correct.
- Check that the seal is seated correctly and adjust if necessary.
- Tighten the fastening screw with approx. 0.6 Nm.
- If possible, the cable should be positioned so that drops of condensation cannot get into the plug via the cable. (see following picture)

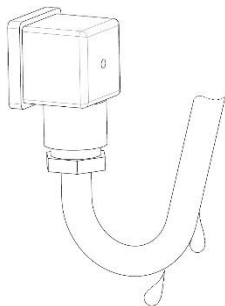

6.4.1 Pin assignment

Plug socket acc. to DIN EN 175301-803.

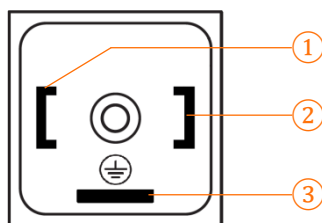



- 1 Supply voltage
- 2 Supply voltage
- 3 Protective conductor / Grounding

7 COMMISSIONING; DECOMMISSIONING; MAINTENANCE

7.1 Commissioning

- Before commissioning, the operating data and materials of the valve must be compared with those of the piping system.
- It must be ensured that the valve and piping are installed correctly and all connections are properly connected.
- For new systems or repairs, the entire piping system must be flushed out to remove foreign substances from the system. This enables to check the resistance of the system.
- Please ensure that the required differential pressure is present between the valve inlet and valve outlet for the corresponding valve types.
- After the first pressure and operating temperature tests, make sure that the valve is leak-proof.
- No work may be carried out on the valve during operation.

	WARNING
	<p>Risk of poisoning and environmental damage from the medium</p> <ul style="list-style-type: none"> ▪ Leakage due to impermissible pipe forces or improper installation of the system.

	WARNING
	<p>Hot surface</p> <p>Coil and valve body heat up during operation.</p> <ul style="list-style-type: none"> ▪ There is a risk of burns when touching hot surfaces. ▪ Avoid touching hot surfaces. If not otherwise possible, wear safety gloves.

	NOTICE
	<p>Destruction of the AC coil due to overheating</p> <p>When commissioning the valve with an AC coil, ensure that the coil is correctly mounted on the plunger.</p>

7.2 Decommissioning

During decommissioning and long downtimes, media that change their aggregate state must be drained or removed from the system. If necessary, the system must be flushed out.

7.3 Maintenance

AWS valves are largely maintenance-free. For operational safety reasons, a visual and functional check of the valve must be carried out every quarter. Special attention must be paid to the following points:

- No change to the normal operating conditions
- Leak tightness
- No unusual operating noises and vibrations

The valve can be cleaned with a wet wipe if necessary.

	NOTICE
	<p>Adjust maintenance interval The maintenance interval must be adapted to the given operating conditions. The responsibility remains with the operator.</p>

7.4 Remove pollutants

There is a risk of coming into contact with harmful substances when working on the valve.

The following warnings must be observed:

	DANGER
	<p>Danger from harmful substances on the valve due to use in contaminated areas</p> <ul style="list-style-type: none"> ▪ Only qualified personnel are permitted to work on contaminated valves. ▪ The prescribed safety clothing must always be worn in the contaminated area. In addition, all safety instructions for handling hazardous substances must be followed. ▪ The valve must be completely decontaminated before any work is carried out. ▪ Plastic parts can be so heavily contaminated that cleaning is no longer sufficient.

7.5 Pressure test the system

The valve is tested for leaks with air or water at the factory. The following warning must be observed:

	CAUTION
	<p>Residues on the valve</p> <ul style="list-style-type: none"> ▪ There may still be residues of the test medium on the contact surfaces of the valve. ▪ Note any possible chemical reactions with the operating medium.

The following warning must be observed during a system pressure test:

	WARNING
	<p>Overpressurization of the valve</p> <ul style="list-style-type: none"> ▪ During a system pressure test, the pressure must not exceed 1.5 times the maximum permissible pressure PS of the valve.

7.6 Eliminate faults and defects

Faults or defects may occur during operation. The following table shows possible causes and the appropriate solution. If faults/defects are not listed or are unclear, please contact the manufacturer.

Malfunction / Defect	Cause* ¹	Solution
Valve leaking	Valve seat leaking.	Replace the valve.
Valve does not close.	Voltage is still present.	Check control voltage.
	Incorrectly installed.	Install the valve in the pipe according to the flow direction.
	Differential pressure between valve inlet and valve outlet too low.* ²	Ensure that the required differential pressure is present between the valve inlet and valve outlet.
	Plunger blocked.	Change valve.
Valve does not open.	Operating pressure too high.	Check operating pressure and set permissible operating pressure if necessary.
	Supply voltage interrupted or too low.	Check power supply/cable connection.
	Nominal voltage and coil voltage are different.	Ensure that the valve is suitable for the intended use.
	Defective coil.	Install a new coil (see 11.1).
	Plunger blocked.	Change valve.
Medium leaks at the pipe connection.	Leaking pipe connection.	Check the pipe connection on the valve. Replace the seal if necessary.

*¹ Faults apply to standard valves (NC) normally closed.

*² Applies to type 220 and 240.

8 DISASSEMBLY

When disassembling the valve, all previously mentioned warnings and instructions apply. Pay particular attention to chapter 6 *Installation* and chapter 7 *Commissioning, decommissioning, maintenance*.

8.1 Prepare disassembly

The following steps must be observed before disassembly:

- Observe applicable warnings and instructions to ensure safe and productive work.
- Pipes must be depressurized, cooled down, emptied and cleaned if necessary. Small spaces in the valve may still contain medium.
- Provide a collection container if there is any residual medium in the pipe.
- Power must be switched off and secured against being switched on again.

8.2 Electrical disassembly

The following steps must be followed during electrical disassembly:

	DANGER
<p>Risk of death due to electrocution</p> <ul style="list-style-type: none"> ▪ Only allow a qualified electrician to carry out work on the electrical system. ▪ Switch off the power supply to the system and secure it against being switched on again. ▪ Never disconnect the plug socket when voltage is applied. 	

- Loosen the fastening screw.
- Disconnect the plug from the magnet.

8.3 Mechanical disassembly

The following steps must be followed during mechanical disassembly:

- To loosen the flange connection, the flange screws must be removed from the flange holes.
- The threaded connection is released by unscrewing the pipes from the valve body.
- The coil should not be used as a lever. The appropriate tool must be used.
- In both cases, secure the valve against falling down.
(Do not secure it to the coil or the plug socket)
- Cover the pipeline if the pipes are not also dismantled or another valve is used. This prevents contamination of the piping system.

9 STORE / REUSE VALVE

After disassembly, the valve can be stored or used in another system. The following guidelines must be observed:

- There must be no residue of the medium in the valve.
- Make sure that the valve is in flawless condition before using it again.
- Valve must be designed for the given operating conditions when used again.
- The information in chapter 5 (*Storage and transportation*) must be observed during storage.

	NOTICE
	<p>Environmental pollution due to residues</p> <ul style="list-style-type: none"> ▪ Ensure that the valve is free of residues of the medium before disposal or storage. ▪ All materials must be disposed of properly in accordance with applicable regulations.



10 DISPOSAL

The following regulations must be observed for the disposal of the valve:

	NOTICE
	<p>Disposal of the valve</p> <ul style="list-style-type: none"> ▪ All valve parts must be disposed of in accordance with the disposal regulations / environmental protection regulations. ▪ Pay attention to residual adhesions and outgassing of the fluids.

11 MAINTENANCE

When maintaining the valve, all the warnings and instructions mentioned above apply. Pay particular attention to chapter 6 *Installation*, chapter 7 *Commissioning, decommissioning, maintenance* and chapter 8 *Disassembly*.

	<p style="text-align: center;">DANGER</p> <p>Risk of death due to electrocution</p> <ul style="list-style-type: none"> ▪ Only allow a qualified electrician to carry out work on the electrical system.
	<p style="text-align: center;">WARNING</p> <p>Risk of injury and poisoning from hazardous or hot media</p> <p>Use personal safety equipment for all work on the valve. Collect leaking medium safely and dispose of it in an environmentally friendly manner.</p>
	<p style="text-align: center;">WARNING</p> <p>Risk of injury during disassembly work</p> <p>Wear protective gloves; components can be very sharp-edged due to wear or damage. Carefully remove components with springs; the spring tension can cause the components to be ejected.</p>

11.1 Coil change

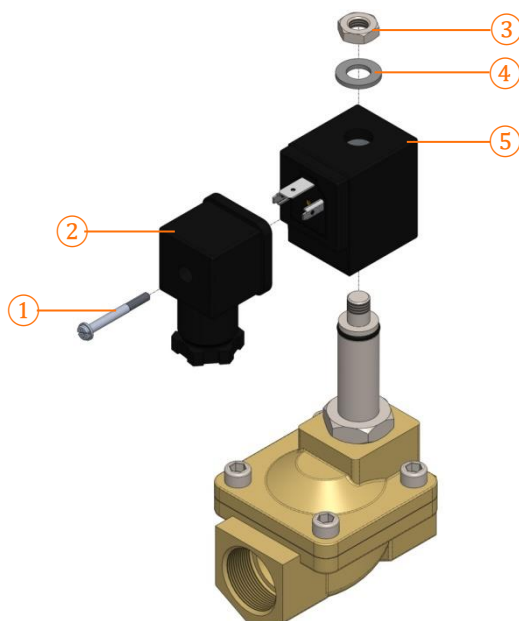

1. Loosen the fastening screw (1) and remove the plug socket (2) from the valve.
2. Unscrew nut (3) and remove washer (4).
3. Remove the magnet (5). Dispose the defective magnet properly.
4. Mount new coil (5).
5. Reassemble the individual parts in reverse order.
6. Electrical connection of the valve (6.4 Electrical connection).
7. Pressure test the system (7.5 Pressure test the system).

11.2 Spare parts

The following information is required when ordering spare parts:

- Item number
- Valve type
- Nominal pressure and nominal diameter
- Body and seal material

	NOTICE
	<p>Improper spare parts Only spare parts from AWS Apparatebau are to be used. Otherwise, proper functioning cannot be guaranteed.</p>

11.3 Reshipment

The following instructions must be followed when returning the valve:

- Cover all valve openings (e.g. with protective foil).
- A declaration of no objection must be completed and enclosed for the return shipment.
- The valve must be packed and transported as described in chapter 5 *Storage and transportation*.

AWS Apparatebau accepts no responsibility for damage caused by unsuitable packaging or transport.

12 DECLARATION OF CONFORMITY

The valves comply with the following directives:

- 2014/68/EU – Pressure Equipment Directive
- 2014/35/EU – Low-Voltage Directive
- 2011/65/EU – RoHS-Directive

The declaration of conformity can be accessed and downloaded at

<https://www.aws-apparatebau.de/>.

13 APPENDIX

13.1 Technical data

Please refer to the data sheet for technical data such as operating pressure or operating temperature. If necessary, this can be requested from the manufacturer.

13.2 Circuit diagram

Type 210 / 210a / 214 / 216 / 219	Type 215
Switch function: NC (normally closed)	Switch function: NO (normally open)
Type 220 / 221 / 240 / 242 / 246	Type 240 / 242
Switch function: NC (normally closed)	Switch function: NO (normally open)
Type 310 / 314 / 317	
Switch function: NC (normally closed)	